



I8288 BUS CONTROLLER FOR iAPX 86, 88 PROCESSORS INDUSTRIAL

- Bipolar Drive Capability
- Provides Advanced Commands
- Provides Wide Flexibility in System Configurations
- 3-State Command Output Drivers
- Configurable for Use with an I/O Bus
- Facilitates Interface to One or Two Multi-Master Busses
- Industrial Temperature Range: -40°C to 85°C

The Intel® I8288 Bus Controller is a 20-pin bipolar component for use with medium-to-large iAPX 86 processing systems. The bus controller provides command and control timing generation as well as bipolar bus drive capability while optimizing system performance.

A strapping option on the bus controller configures it for use with a multi-master system bus and separate I/O bus.

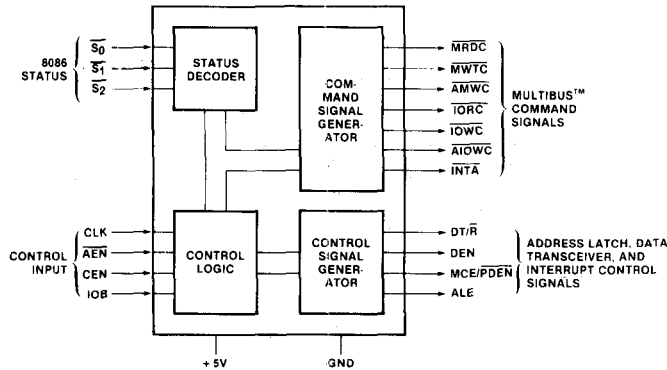

Figure 1. Block Diagram

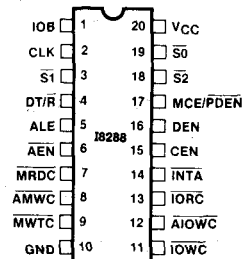

Figure 2. Pin Configuration

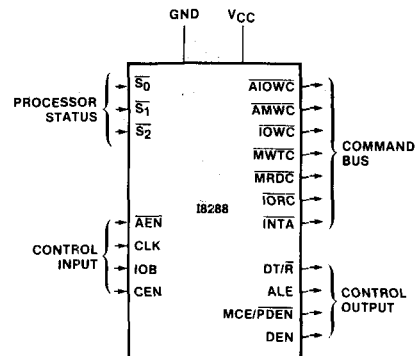

Figure 3. Functional Pin-Out

ABSOLUTE MAXIMUM RATINGS*

Temperature Under Bias -40°C to 85°C
 Storage Temperature -65°C to +150°C
 All Output and Supply Voltages -0.5V to +7V
 All Input Voltages -1.0V to 5.5V
 Power Dissipation 1.5 Watt

**NOTICE: Stresses above those listed under "Absolute Maximum Ratings" may cause permanent damage to the device. This is a stress rating only and functional operation of the device at these or any other conditions above those indicated in the operation sections of this specification is not implied. Exposure to absolute maximum rating conditions for extended periods may affect device reliability.*

D.C. CHARACTERISTICS ($V_{CC} = 5V \pm 10\%$, $T_A = -40^\circ C$ to $85^\circ C$)

Symbol	Parameter	Min.	Max.	Unit	Test Conditions
V_C	Input Clamp Voltage		-1	V	$I_C = -5\text{ mA}$
I_{CC}	Power Supply Current		230	mA	
I_F	Forward Input Current		-0.7	mA	$V_F = 0.45V$
I_R	Reverse Input Current		50	μA	$V_R = V_{CC}$
V_{OL}	Output Low Voltage		0.5	V	$I_{OL} = 20\text{ mA}$ $I_O = 16\text{ MA}$
	Command Outputs Control Outputs		0.5	V	
V_{OH}	Output High Voltage	2.4		V	$I_{OH} = -5\text{ mA}$ $I_{OH} = -1\text{ mA}$
	Command Outputs Control Outputs	2.4		V	
V_{IL}	Input Low Voltage		0.8	V	
V_{IH}	Input High Voltage	2.0		V	
I_{OFF}	Output Off Current		100	μA	$V_{OFF} = 0.4\text{ to }5.25V$

A.C. CHARACTERISTICS ($V_{CC} = 5V \pm 10\%$, $T_A = -40^\circ C$ to $85^\circ C$)

TIMING REQUIREMENTS

Symbol	Parameter	Min.	Max.	Unit	Test Conditions
TCLCL	CLK Cycle Period	125		ns	
TCLCH	CLK Low Time	66		ns	
TCHCL	CLK High Time	40		ns	
TSVCH	Status Active Setup Time	35		ns	
TCHSV	Status Active Hold Time	10		ns	
TSHCL	Status Inactive Setup Time	35		ns	
TCLSH	Status Inactive Hold Time	10		ns	
TILIH	Input Rise Time		20	ns	From 0.8V to 2.0V
TIHIL	Input Fall Time		12	ns	From 2.0V to 0.8V

A.C. CHARACTERISTICS (Continued)

TIMING RESPONSES

Symbol	Parameter	Min.	Max.	Unit	Test Conditions	
TCVNV	Control Active Delay	5	45	ns	MRDC IORC MWTC IOWC INTA AMWC AIOWC } $I_{OL} = 20\text{ mA}$ $I_{OH} = +5\text{ mA}$ $C_L = 300\text{ pF}$	
TCVNX	Control Inactive Delay	10	50	ns		
TCLLH, TCLMCH	ALE MCE Active Delay (from CLK)		25	ns		
TSVLH, TSVMCH	ALE MCE Active Delay (from Status)		25	ns		
TCHLL	ALE Inactive Delay	4	15	ns		
TCLML	Command Active Delay	10	35	ns		
TCLMH	Command Inactive Delay	10	35	ns		
TCHDTL	Direction Control Active Delay		50	ns		
TCHDTH	Direction Control Inactive Delay		30	ns		
TAELCH	Command Enable Time		40	ns		Other } $I_{OL} = 16\text{ mA}$ $I_{OH} = -1\text{ mA}$ $C_L = 80\text{ pF}$
TAEHCZ	Command Disable Time		40	ns		
TAELCV	Enable Delay Time	115	200	ns		
TAEVNV	AEN to DEN		20	ns		
TCEVNV	CEN to DEN, PDEN		25	ns		
TCELRH	CEN to Command		TCLML	ns		
TOLOH	Output Rise Time		20	ns	From 0.8V to 2.0V	
TOHOL	Output Fall Time		12	ns	From 2.0V to 0.8V	

A.C. TESTING INPUT, OUTPUT WAVEFORM

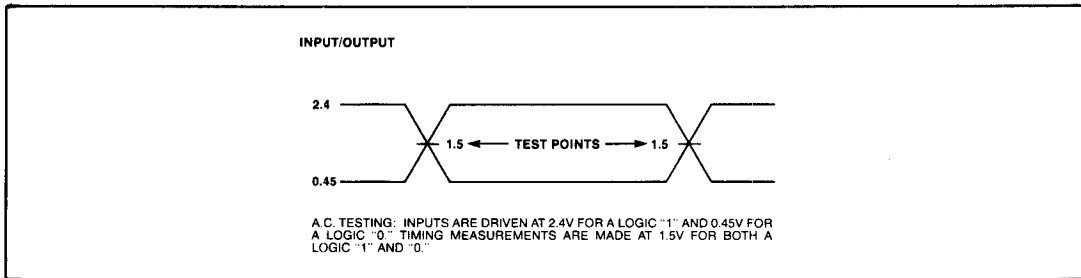

TEST LOAD CIRCUITS—3-STATE COMMAND OUTPUT TEST LOAD

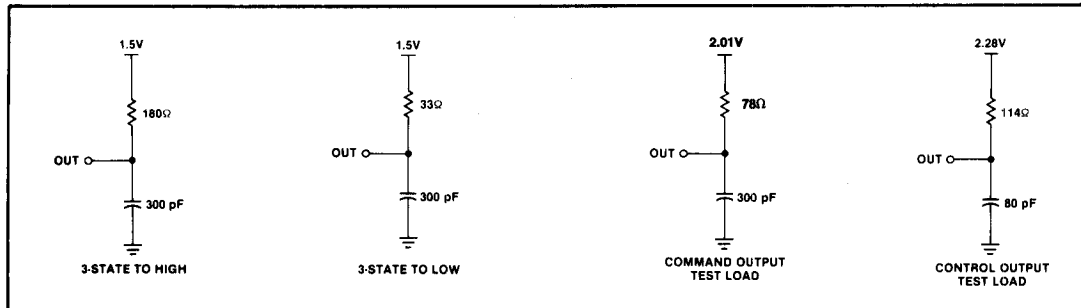

WAVEFORMS

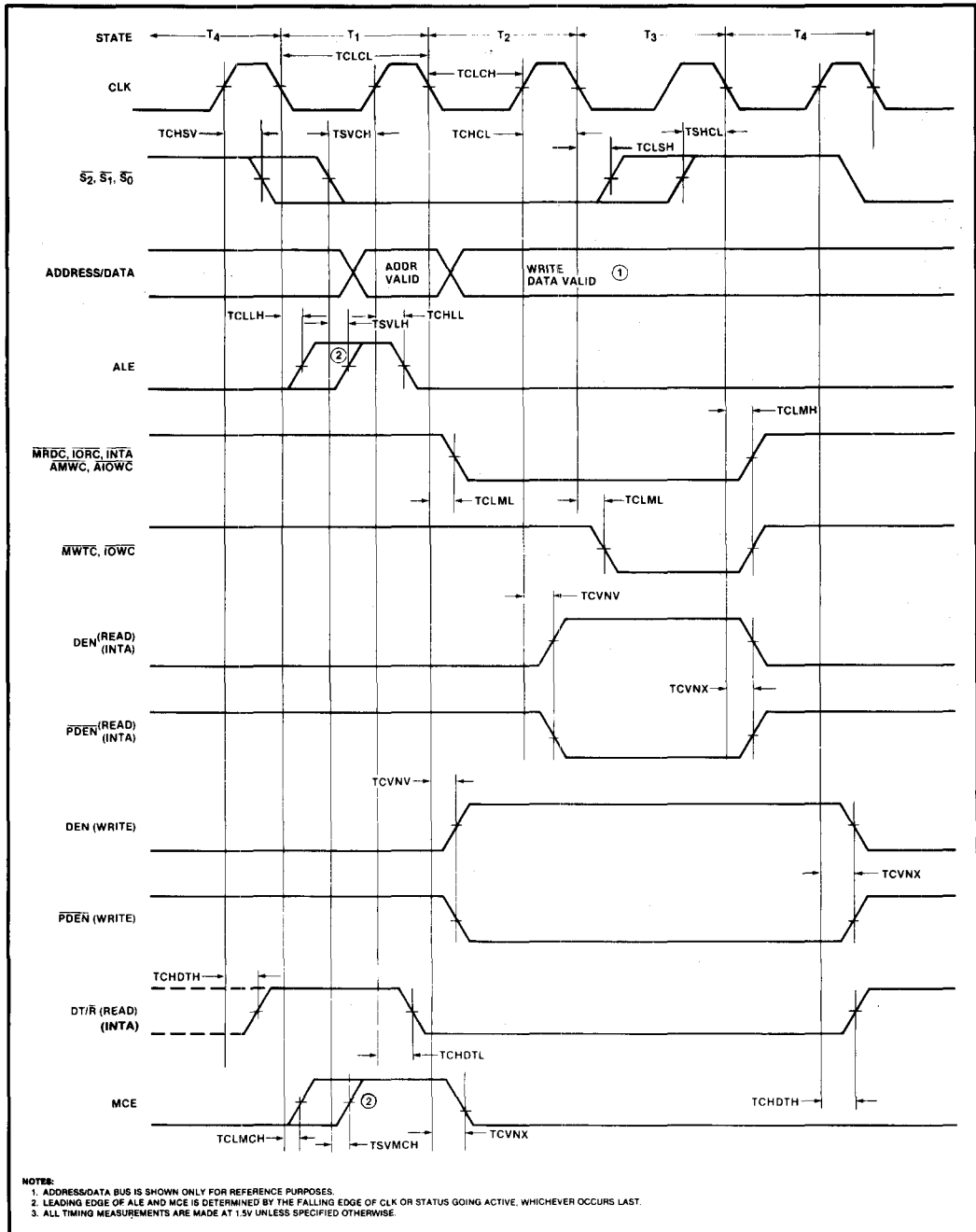

WAVEFORMS (Continued)

