



M8214

PRIORITY INTERRUPT CONTROL UNIT

Military

- Not Recommended for New Designs
- 8 Priority Levels
- Fully Expandable
- Current Status Register
- Priority Comparator
- 24-Pin Dual-In-Line Package
- Military Temperature Range:
-55°C to +125°C (T_C)
- ± 10% Power Supply Tolerance

The Intel M8214 is an 8-level priority interrupt control unit (PICU) designed to simplify interrupt-driven micro-computer systems.

The PICU can accept 8 requesting levels; determine the highest priority, compare this priority to a software controlled current status register and issue an interrupt to the system along with vector information to identify the service routine.

The M8214 is fully expandable by the use of open collector interrupt output vector information. Control signals are also provided to simplify this function.

The PICU is designed to support a wide variety of vectored interrupt structures and reduce package count in interrupt-driven microcomputer systems.

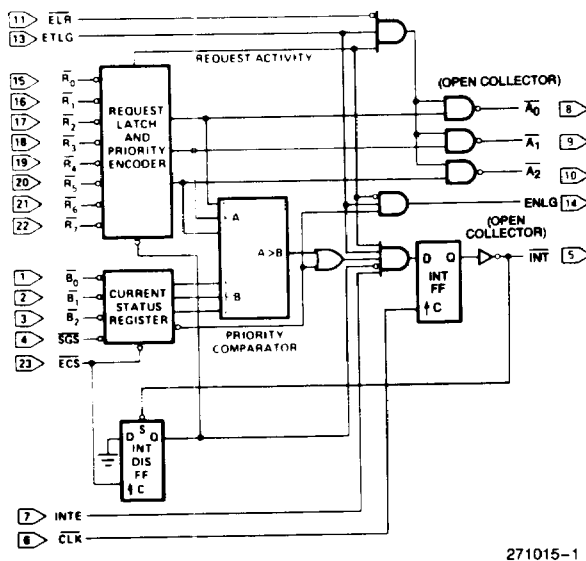
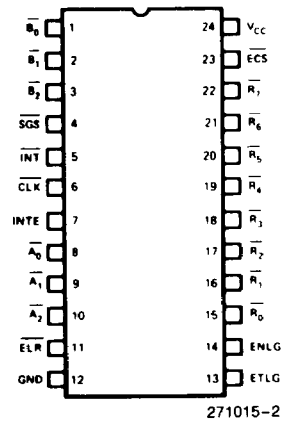

Figure 1. Logic Diagram



INPUTS	
R ₀ -R ₇	Request Levels (R ₇ Highest Priority)
B ₀ -B ₂	Current Status
SGS	Status Group Select
ECS	Enable Current Status
INTE	Interrupt Enable
CLK	Clock (INT FF)
ELR	Enable Level Read
ETLG	Enable This Level Group
OUTPUTS	
A ₀ -A ₂	Request Levels
INT	Interrupt (Act Low) Open Collector
ENLG	Enable Next Level Group

Figure 2. Pin Configuration

ABSOLUTE MAXIMUM RATINGS*

Case Temperature Under Bias⁽¹⁾. -55°C to +125°C
 Storage Temperature -65°C to +160°C
 All Output and Supply Voltages -0.5V to +7V
 All Input Voltages..... -1.0V to +5.5V
 Output Currents 100 mA

**Notice: Stresses above those listed under "Absolute Maximum Ratings" may cause permanent damage to the device. This is a stress rating only and functional operation of the device at these or any other conditions above those indicated in the operational sections of this specification is not implied. Exposure to absolute maximum rating conditions for extended periods may affect device reliability.*

D.C. CHARACTERISTICS $T_C^{(1)} = -55^\circ\text{C}$ to $+125^\circ\text{C}$, $V_{CC} = +5\text{V} \pm 10\%$

Symbol	Parameter	Limits			Units	Conditions
		Min	Typ ⁽¹⁾	Max		
V_C	Input Clamp Voltage (All Inputs)			-1.2	V	$I_C = -5\text{ mA}$
I_F	Input Forward Current: ETLG Input All Other Inputs		-0.15 -0.08	-0.5 -0.25	mA mA	$V_F = 0.45\text{V}$
I_R	Input Reverse Current: ETLG Input All Other Inputs			80 40	μA μA	$V_R = 5.5\text{V}$
V_{IL}	Input LOW Voltage: All Inputs			0.8	V	$V_{CC} = 5.0\text{V}$
V_{IH}	Input HIGH Voltage: All Inputs	2.0			V	$V_{CC} = 5.0\text{V}$
I_{CC}	Power Supply Current		90	130	mA	(Note 2)
V_{OL}	Output LOW Voltage: All Outputs		0.3	0.45	V	$I_{OL} = 10\text{ mA}$
V_{OH}	Output HIGH Voltage: ENLG Output	2.4	3.0		V	$I_{OH} = -1\text{ mA}$
I_{OS}	Short Circuit Output Current: ENLG Output	-15	-35	-55	mA	$V_{CC} = 5.0\text{V}$
I_{CEX}	Output Leakage Current: \overline{INT} , $\overline{A_0}$, $\overline{A_1}$, $\overline{A_2}$			100	μA	$V_{CEX} = 5.5\text{V}$

CAPACITANCE $V_{BIAS} = 2.5\text{V}$, $V_{CC} = 5\text{V}$, $T_C^{(1)} = 25^\circ\text{C}$, $f = 1\text{ MHz}$

Symbol	Parameter	Limits			Units
		Min	Typ ⁽¹⁾	Max	
C_{IN}	Input Capacitance		5	10	pF
C_{OUT}	Output Capacitance Except ENLG (Pin 14)		7	12	pF

NOTE:

1. Case temperatures are "instant on".